

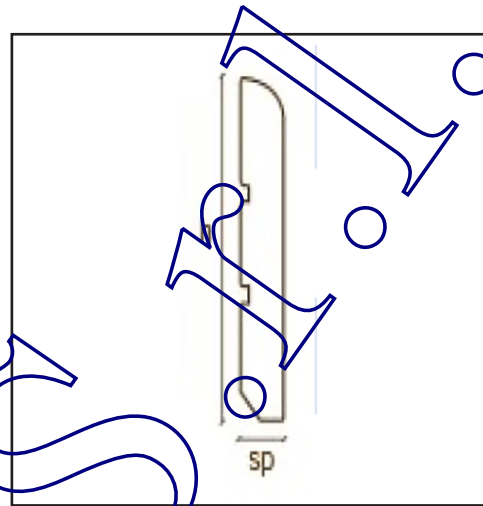

Wood Flooring Production

Stemau S.r.l.
 Legal Head Office and Showroom Via Pieve Ligure, 15 00168 Rome
 Warehouse and Showroom Via Refrancore, 26 00166 Rome
 Factory Via Morsasco, 41 00166 Rome
 Phone 0039.06.45.50.22.60 - info@stemausrl.it - www.stemausrl.it
 VAT 01814361000 - Fiscal Code 0778980388

INFORMATION SHEET In compliance with the provisions of the law Legislative Decree no. 206/2005 "Regulations for consumer information"

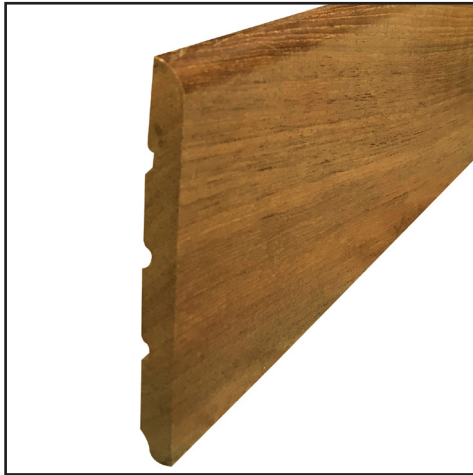

SUITABLE FOR ALL INTERNAL ENVIRONMENTS

ROUND-EDGE SKIRTING BOARD

TYPE: SOLID

WOOD SPECIES: AFRORMOSIA OR AFZELIA OR IROKO OR OAK OR TEAK OR WENGE' OR ZEBRANO

FINISHING: TRANSPARENT MATT WITH POLYURETHANE VARNISH

COLOR TONE: SUBJECT TO CHANGE

FIXING: GLUE OR SILICONE OR CONCEALED PINS

DIMENSIONS: 75x10 mm OR 95x10 mm (HEIGHT/THICKNESS)

PACK: 10 PIECES

RESISTANCE TO ATTACKS BY FUNGI AND/OR INSECTS: GOOD

ON DEMAND THERE ARE OTHER DIMENSIONS AND OTHER WOOD SPECIES AVAILABLE

Storage

The product must absolutely be stored with intact packaging and closed in covered, dry environments and heated to a temperature of about 20°C and with relative ambient humidity between about 45% and 60%.

Maintenance

For good maintenance, clean with a damp cloth, using a neutral, non-foaming detergent.

Avoid washing with boiling water and/or steam-producing appliances.

Disposal

The product must not be dispersed into the environment, but entrusted to public waste disposal systems.